

PRINTER SPECIFICATIONS

MARK TWO

Replace machined aluminum tooling - jigs, jaws and fixtures - with stronger parts for a fraction of the price. The Mark Two combines Markforged's unique continuous carbon fiber reinforcement with workhorse reliability for versatile parts with 23x the strength of ABS, ready same-day for use straight off the printer.

PRINTER PROPERTIES	Process	Continuous Fiber Reinforced Plastics
	Build Volume	320 x 132 x 154 mm (12.6 x 5.2 x 6 in)
	Weight	16 kg (35 lbs)
	Machine Footprint	584 x 330 x 355 mm (23 x 13 x 14 in)
	Print Bed	Flat to within 160 um - Kinematic coupling
	Power	100-240VAC, 150W (2A peak)
PART PROPERTIES	Layer Height	100um default, 200um maximum
	Ultimate Tensile Strength	700 MPa (22.6x ABS, 19.4x Onyx)
	Max Flexural Stiffness	51 GPa (24.8x ABS, 17.6x Onyx)
	Infill	Closed Cell Infill: Multiple geometries available
SOFTWARE	Supplied Software	Markforged Software - Cloud Storage, Local Storage, or Fully On-Premise (\$5,000 added fee)
	Security	Two Factor Auth, Org Admin Access, Single Sign On
MATERIALS	Plastics Available	Onyx
	Fibers Available	Carbon Fiber, Fiberglass, Kevlar, High Strength/High Temp Fiberglass

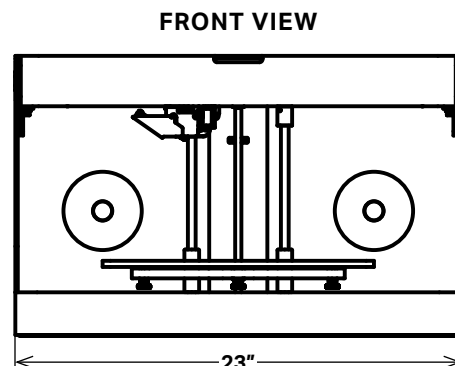
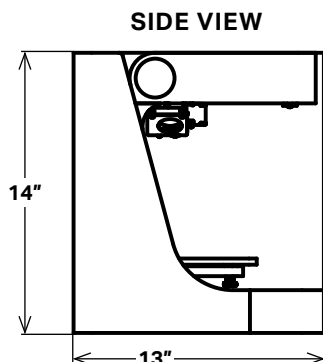

All specifications approximate and subject to change without notice.